

Parts Manual for

SNAPPER®

EUROPEAN ZERO TURN HYDRO DRIVE 18.5 HP 42" 150Z SERIES

MODEL

EZT18542150ZBVE (2690612)

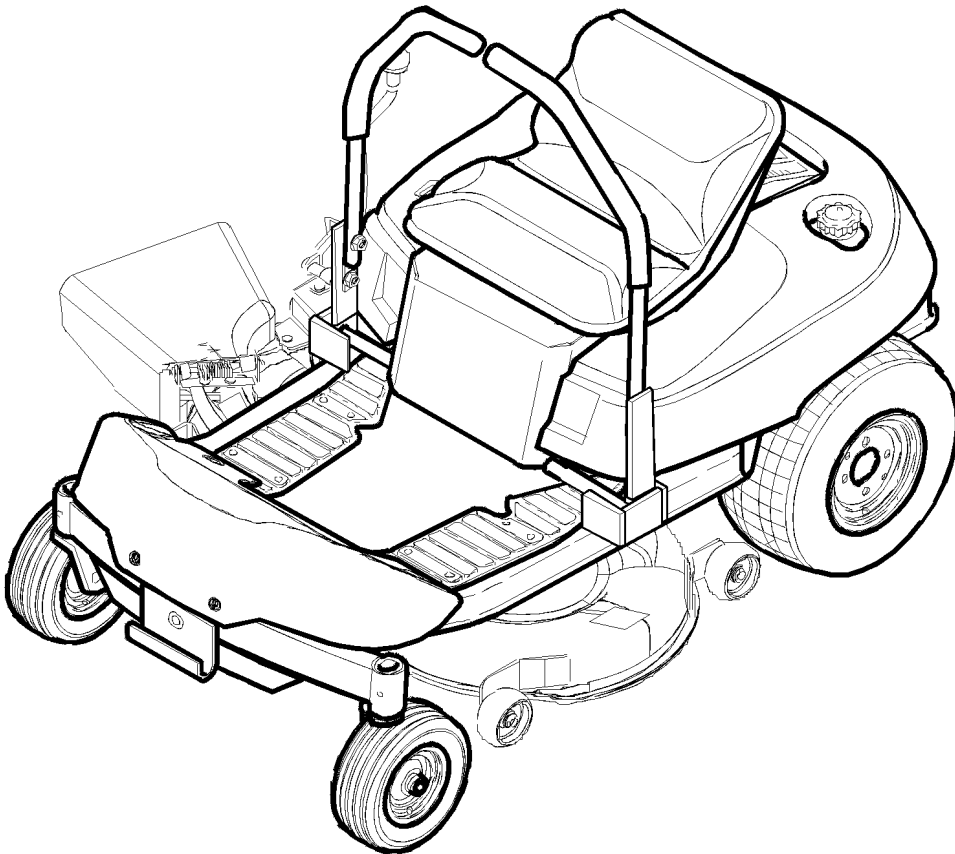

SNAPPER® McDonough, GA, 30253 U.S.A.

PAGE	GROUP
4	Frame, Body & Seat Group
8	Engine Group
10	Carrier & Transmission Group
14	Controls Group
18	Wheel & Tire Group
20	Decals Group
22	42" Mower Deck - Clutch & Support Group
24	42" Mower Deck - Height Adjustment Group
28	42" Mower Deck - Housing & Arbor Group
30	Electrical Group

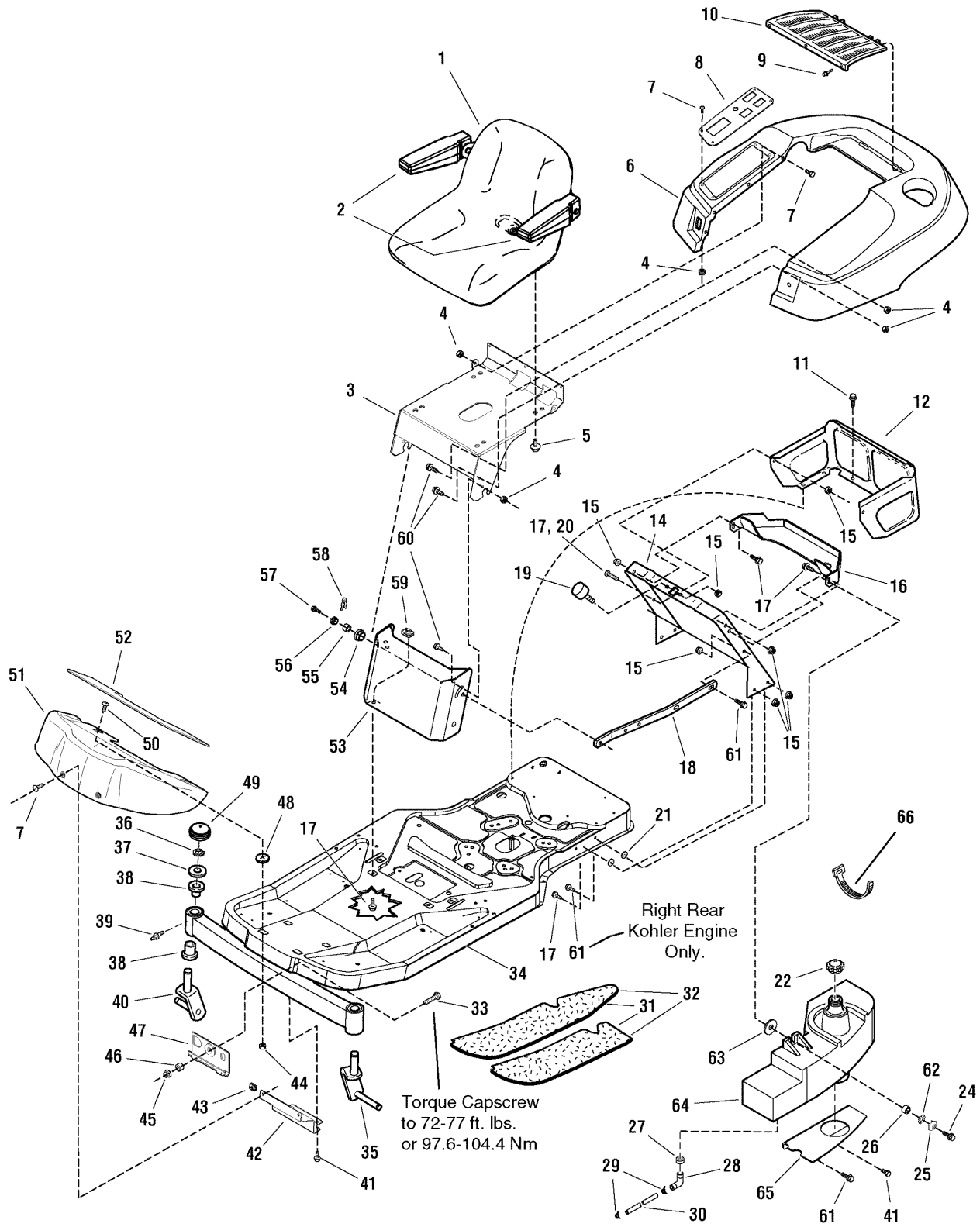

Frame, Body & Seat Group

Item	Part No	Qty	Description	Note
1	1726018	1	SEAT ASSEMBLY, with Arm Rests	(Includes Ref. No. 2)
2	1687021	1	ARM REST KIT, (L.H. & R.H.)	
3	1727332A	1	SUPPORT, Seat	
4	1960694	12	NUT, Hex Flange ESNA, 1/4-20	
5	1960738	4	CAPSCREW, Hex Head Whiz Lock Dog Point, 5/16-18 x 3/4	
6	1726649	1	DECK, Seat	
7	1960715	8	SCREW, Truss Head Torx Drive, 1/4-20 x 3/4	
8	1727699A	1	PLATE, Pod Control	
9	1673320	3	RIVET, Pop	
10	1708504	1	SCREEN, Seat Deck	
11	1925003	6	CAPSCREW, Hex Washer Head Taptite, 1/4-20 x 1/2	
12	1715962A	1	SHROUD, Rear	
14	1732974A	1	SUPPORT, Seat Deck	
15	1931277	8	NUT, Hex Flange Whiz Lock, 5/16-18	
16	1734180A	1	DUCT, Air Inlet	
17	1930591	10	CAPSCREW, Hex Head Whix Lock, 5/16-18 x 3/4, G5	
18	1727810A	1	BRACE, Tank	
19	1726390	2	BUMPER, Rubber	
20	1933689	1	CAPSCREW, Hex Head Whiz Lock, 5/16-18 x 1-1/2, G5	
21	1933988	4	NUT, Push	
22	1714020	1	CAP, Fuel Tank	
24	1930600	1	CAPSCREW, Hex Washer Head Taptite, 5/16-18 x 1-1/2	
25	1919381	3	WASHER, 5/16	
26	1710437	1	SPACER	
27	1726400	1	BUSHING, Fuel Tank	
28	1674792	1	ELBOW, with Screen, Gas Tank to Fuel Line	
29	2860112	2	CLAMP, Hose, Wire Type E	
30	1733008	1	HOSE, Fuel 8.5" Long	
31	1728986	1	PAD, Footrest, R.H.	
32	1728987	1	PAD, Footrest, L.H.	
33	1920328	1	CAPSCREW, Hex Head, 1/2-13 x 1-1/2, G5	
34	1734006A	1	FRAME & SPINDLES ASSEMBLY	(Includes Ref. Nos. 35, 36, 37, 38, 39 & 40)
35	1716065	1	ARM, Caster, L.H.	
36	2834712	2	RING, E-Retaining	
37	1919394	4	WASHER	
38	1721682	4	BUSHING	
39	1704314	2	LUBE FITTING, 1/4 Drive w/Check Ball	

Footnotes:

Frame, Body & Seat Group

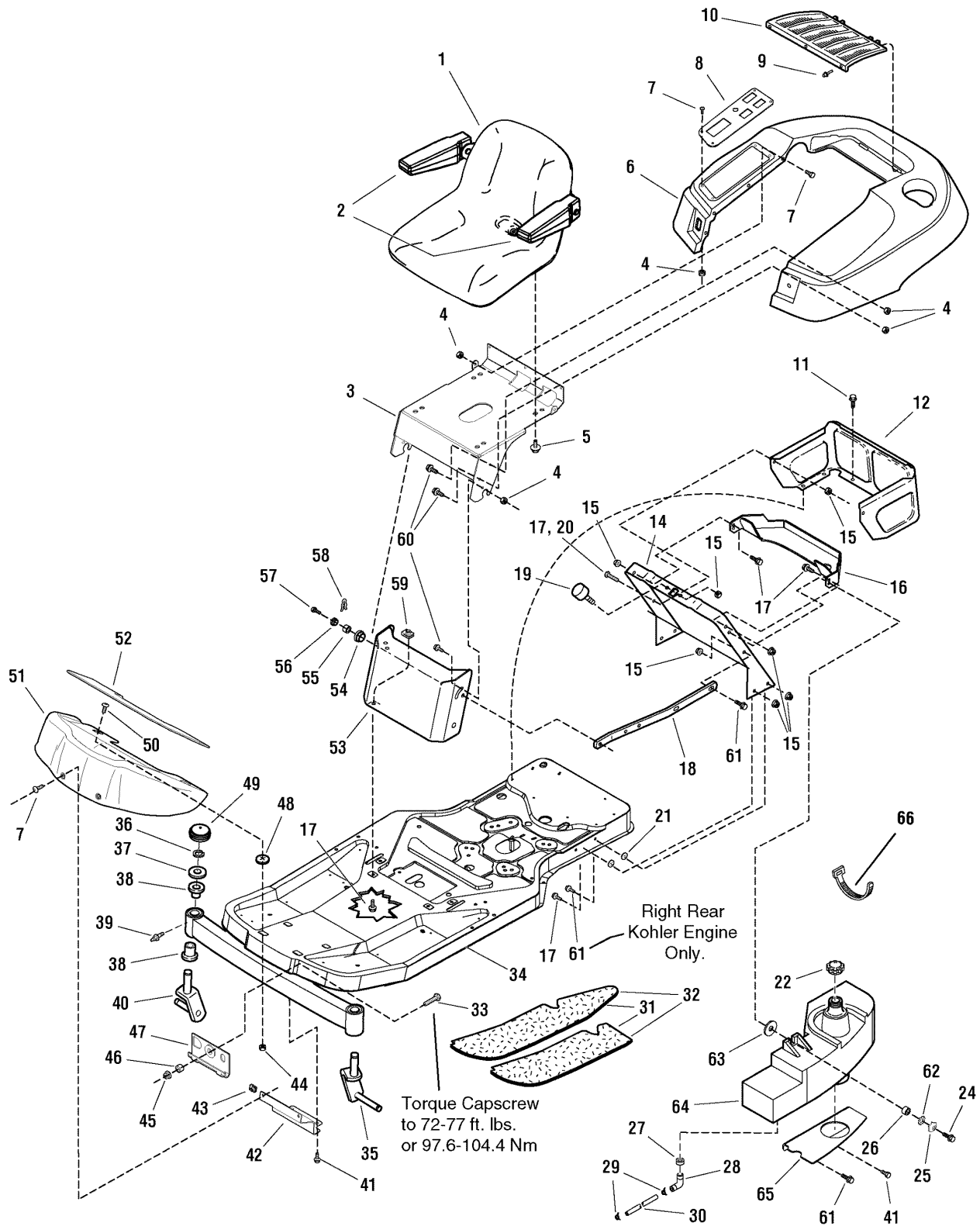

Frame, Body & Seat Group

Item	Part No	Qty	Description	Note
40	1716066	1	ARM, Caster, R.H.	
41	1664847	3	SCREW, Hex Washer Head Taptite, 5/16-18 x 3/4	
42	1726024A	1	BRACKET, Footrest Support	
43	1960368	2	NUT, Speed Lug Type, 1/4-20	
44	1930641	2	NUT, Hex Flange Whiz Lock, 1/4-20	
45	1930644	1	NUT, Hex Flange Two-Way Lock, 1/2-13	
46	1709235	1	SPACER	
47	1716064A	1	HOOK & WASHER ASSEMBLY	
48	1960518	2	NUT, Push, 1/4	
49	1726504	2	CAP, Hub	
50	1931317	2	CARRIAGE BOLT, 1/4-20 x 3/4	
51	1726025D	1	PANEL, Footrest	
52	1726306	1	PAD, Footrest, Front	
53	1727685A	1	PANEL, Front	
54	1704626	2	SPACER	
55	1705249	2	SPACER	
56	1705248	2	PIVOT, Hood	
57	1704628	2	PIN, Quick	
58	1960373	2	CAPSCREW, Hex Washer Head Taptite, 5/16-18 x 1	
59	1935255	4	NUT, Speed Lug Type, 5/16-18	
60	1960295	6	SCREW, Hex Flange Whiz Lock, 1/4-20 x 5/8	
61	1930595	1	CAPSCREW, Hex Flange Whiz Lock, 5/16-18 x 1-1/4, G5	
62	2820427	1	LOCKWASHER, External Tooth, 3/8	
63	1960071	1	WASHER, 3/8 x 1-1/4 x 1/4	
64	1726635	1	TANK, Fuel	
65	1732975A	1	BRACKET, Fuel Tank	
66	1701011	1	TIE, Self-Locking	

Footnotes:

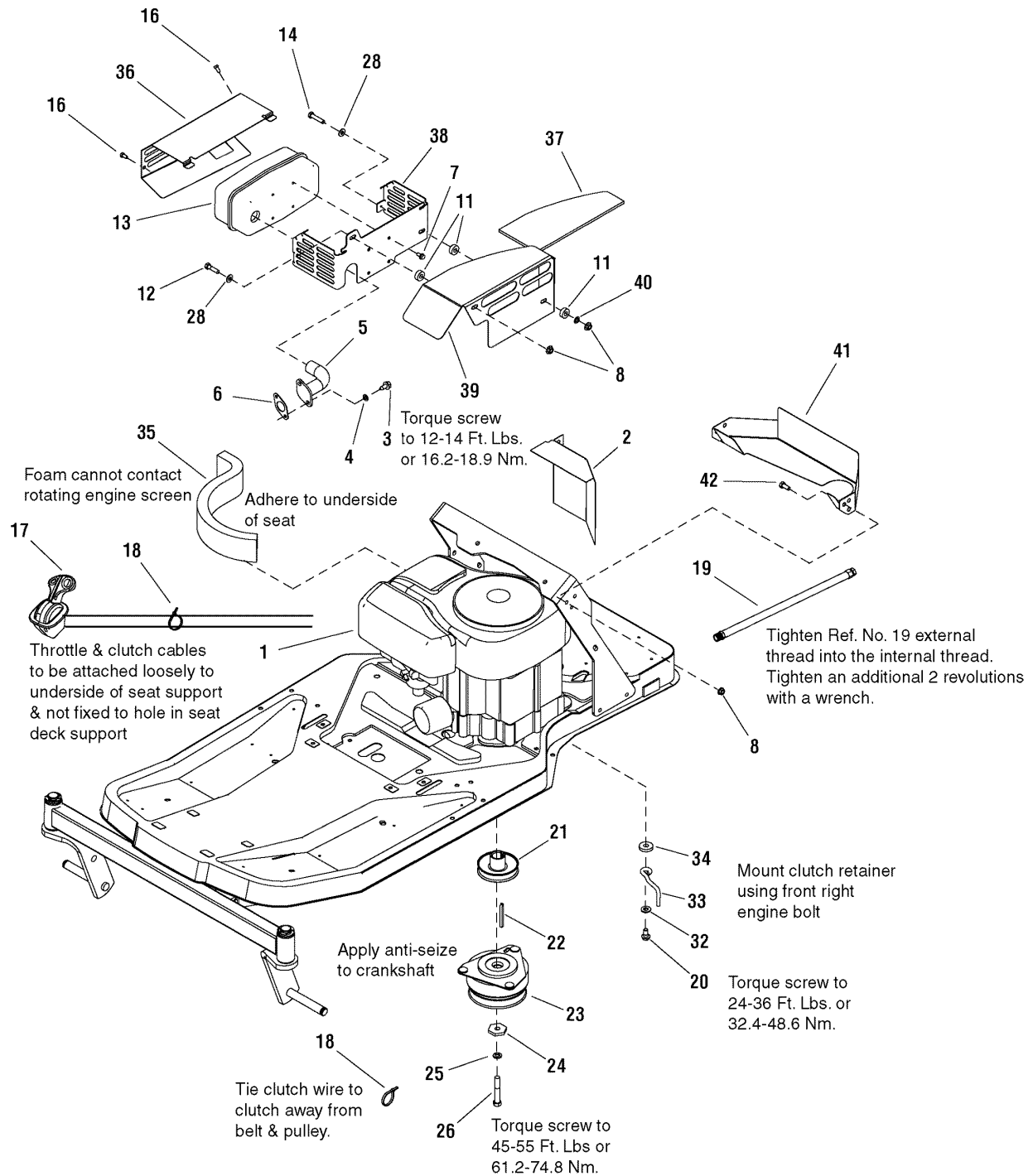

Engine Group

Item	Part No	Qty	Description	Note
1	--	1	* ENGINE, 18.5HP B&S Intek Model 31Q777-0113-B1	
2	1732257A	1	SHIELD, Heat Inner	
3	1936228	2	CAPSCREW, Hex Socket Head, 5/16-18 x 3/4, G8	
4	1917356	2	LOCKWASHER, Spring 5/16	
5	1732259	1	PIPE, Exhaust B&S Intek	
6	1731214	1	GASKET, Exhaust B&S	
7	1960295	4	CAPSCREW, Hex Whiz Lock Flange, 1/4-20 x 5/8	
8	1927557	2	NUT, Hex Flange Whiz Lock, 5/16-18 Large	
11	1667811	1	SPACER	
12	1921977	1	CAPSCREW, Hex Head, 5/16-18x 1-1/4, G5	
13	1732273	1	MUFFLER, B&S	
14	1921221	1	CAPSCREW, Hex Head, 5/16-18 x 1-1/2, G5	
16	1960720	4	CAPSCREW, Hex Washer Head, #10 x 1/2	
17	1727817	1	CONTROL, Throttle Double 42" Long	
18	2832747	2	TIE, Self-Locking 3-5/8 Long	
19	1726498	1	HOSE, Oil Drain 16-1/2 Long	
20	2830598	3	CAPSCREW, Hex Washer Head Taptite, 3/8-16 x 1-1/2	
21	1727816	1	PULLEY, 3-3/4	
22	1720463	1	KEY, HI-PRO, 1/4 x 1/4	
23	1686880	1	CLUTCH, # 504586, Electric, OGURA JD-11	
24	1708264	1	WASHER, Special Hex	
25	1918199	1	LOCKWSHER, Spring, 7/16	
26	1960648	1	CAPSCREW, Hex Head, 7/16-20 x 2-3/4, G5	
28	1919326	1	WASHER, 5/16	
32	1924940	1	WASHER, 3/8 x .08 THK	
33	1732026	1	RETAINER, Clutch	
34	1933263	1	WASHER, 7/16 x 1/4 THK	
35	1734189	1	SEAL, Foam Air Duct	
36	1734032A	1	HEAT SHIELD, Single	
37	1734062	1	INSULATION SHIELD, Top Muffler	
38	1734017A	1	MUFFLER BRACKET/HEAT SHIELD	
39	1734044A	1	GUARD, Muffler	
40	1933988	1	NUT, Push Pal, 5/16 x 5/8	
41	1734180A	1	AIR DUCT, Inlet	
42	1921332	1	CAPSCREW, Hex Head, 5/16 - 18 x 3/4	

Footnotes:

Note: * See your local Briggs & Stratton distributor for parts and service.

Carrier & Transmission Group

Item	Part No	Qty	Description	Note
1	1960687	2	NUT, Hex Flange ESNA, 3/8-16	
2	1960684	2	NUT, Hex Keps, 5/16-18	
3	1703900	2	SPACER	
4	1960223	4	CARRIAGE BOLT, 5/16-18 x 1, G5	
5	1727555	1	ROD, Control, L.H.	
6	1919381	4	WASHER, 5/16	
7	1728060	1	HYDRO SEAL KIT	
8	1727831	2	BOLT, Shoulder, 7/16-14, G5	
9	1727556	1	ROD, Control, R.H.	
10	1727795A	2	SPACER	
11	2860398	2	CAPSCREW, Hex Head, 7/16-14 x 8, G5	
12	1918267	4	WASHER, 7/16	
13	1727806	1	TRANSMISSION, Hydro Gear, L.H.	
14	1930650	2	NUT, Hex Flange, 7/16-14, Two-Way Lock	
16	1960686	7	NUT, Hex Flange, 5/16-18 ESNA	
17	1727464A	1	SUPPORT, Center Transmission	
18	1923141	4	CAPSCREW, Hex Head, 5/16-18 x 2-3/4, G5	
19	1732595A	1	FRAME ASSEMBLY, Carrier Transmission	
20	1727767	1	ROD, Actuator, R.H. E-Coat	
21	1725550	1	CLIP, Rod End Clevis L.H.	
22	1921176	2	CAPSCREW, Hex Head, 1/2-13 x 1-1/4, G5	
23	1719725	1	SPACER	
24	1727766	1	ROD, Actuator, L.H.	
25	1730177	1	SPRING, Extension	
26	1677135A	1	GUARD, Belt	
27	1921972	1	CAPSCREW, Hex Head, 3/8-16 x 2-1/4, G5	
28	1728076	1	GEAR, Parking Brake, Transmission	
29	1716622	1	CLIP, E Transmission Parking Brake	
30	1919326	7	WASHER, 5/16	
31	1715971A	1	ARM, Idler	
32	1713588	1	SPACER, Powdered Metal	
33	1721133	1	PULLEY, Idler	
34	1731909	1	KIT, Breather 60 Degree Elbow	
35	1731908	1	KIT, Breather 90 Degree Elbow	
36	1921719	5	CAPSCREW, Hex Head, 5/16-18 x 2-1/2, G5	
37	1719683	1	SPACER	
38	1931277	4	NUT, Hex Whiz Lock Flange, 3/8-16	

Footnotes:

Carrier & Transmission Group

Item	Part No	Qty	Description	Note
39	1930644	2	NUT, Hex Flange, 1/2-13, Two-Way Lock	
40	1924361	2	WASHER, 1/2	
41	1727807	1	TRANSMISSION, Hydro Gear, R.H.	
42	1732224	1	V-BELT	
43	1924940	3	WASHER, 3/8	
44	1960734	2	NUT, Hex Centerlock Jam, 7/16-14	
45	1717024	1	CLIP, Rod End Clevis R.H.	
46	1930633	1	NUT, Hex Head Center Lock	
47	1728073	1	PULLEY, 4.5", Transmission	
48	1728074	1	FAN, 6", Transmission	
49	1925592	1	CAPSCREW, Hex Head, Transmission	
50	1728075	1	PARKING BRAKE ARM ASSEMBLY, Transmission L.H. or R.H.	
51	1687283	2	HUB REPLACEMENT KIT	
52	1733870	2	HUB, EZT Transmissions	
53	5020601	8	NUT, EZT Transmissions	
54	1735490	1	ARM, Control Kit L.H.	
55	1735491	1	ARM, Control Kit R.H.	
56	1735483	2	SPRING, Extension	

Footnotes:

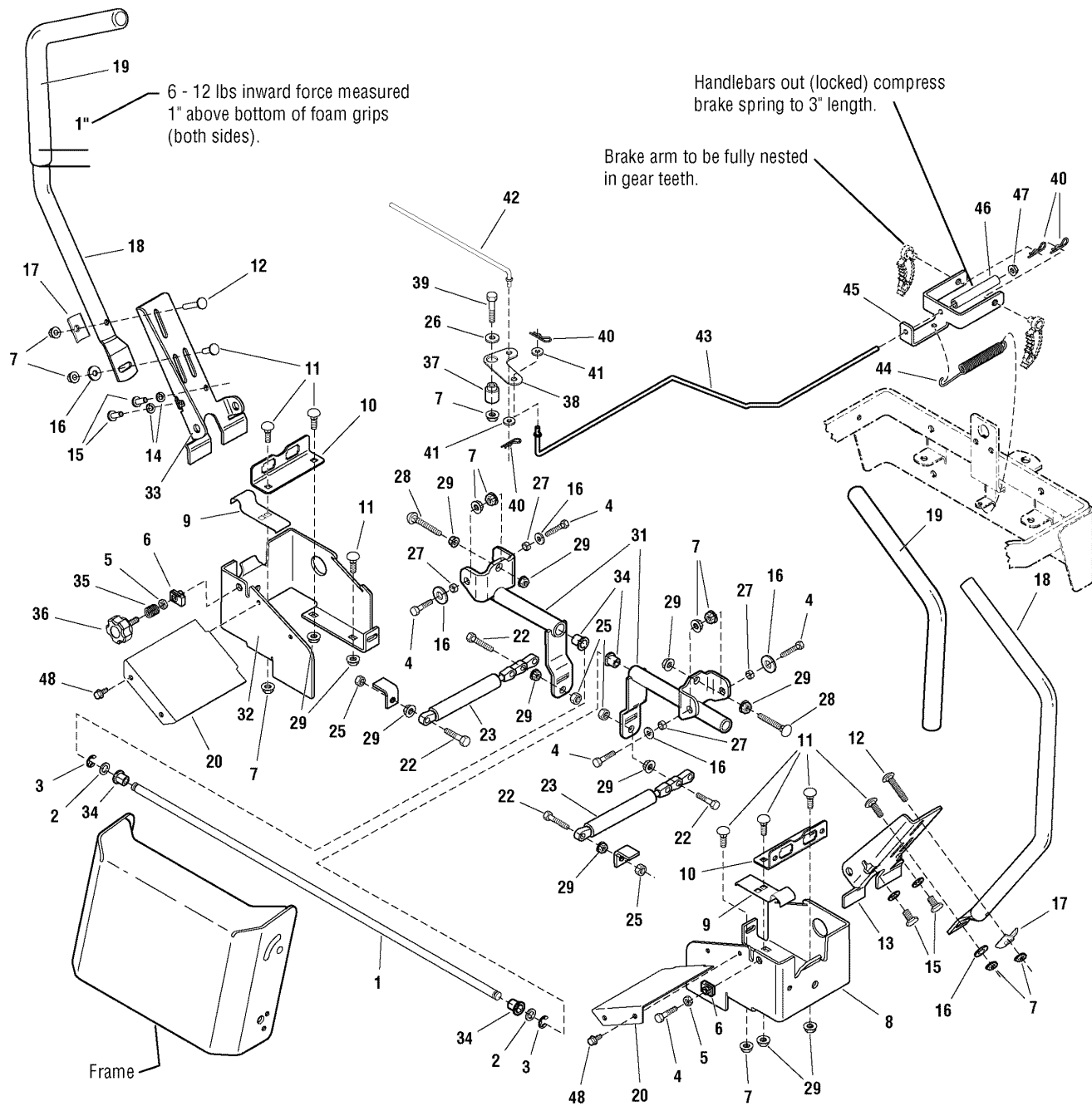

Controls Group

Item	Part No	Qty	Description	Note
1	1725927	1	SHAFT, Cross	
2	1960027	2	WASHER, 1/2	
3	1703805	2	RING, Klipring Extension	
4	1921977	5	CAPSCREW, Hex Head, 5/16-18 x 1-1/4, G5	
5	1920161	6	NUT, Hex Jam, 5/16-18	
6	1960717	2	NUT, Speed, 5/16-18 Lug Type	
7	1960686	15	NUT, Hex Flange, 5/16-18 ESNA	
8	1728009A	1	BRACKET, L.H. Mounting Handle Pivot	
9	1727919	2	CLIP, Brake	
10	1727663A	2	BRACKET, "L" Switch	
11	1931335	8	CARRIAGE BOLT, 5/16-18 x 1, G5	
12	1931338	2	CARRIAGE BOLT, 5/16-18 x 1-3/4, G5	
13	1727926A	1	BRACKET, Tube Mount L.H.	
14	1917356	4	LOCKWASHER, Spring, 5/16	
15	1960086	4	SCREW, Truss Head Torx Drive, 5/16-18 x 7/8	
16	1919381	6	WASHER, 5/16	
17	1720452	2	CLAMP, Saddle Snow Handle, E-Coat	
18	1727796A	2	TUBE, Handle	
19	1726410	2	GRIP, Foam Handle	
20	1727933A	2	COVER, Lower Handle	
22	1921221	4	CAPSCREW, Hex Head, 5/16-18 x 1-1/2, G5	
23	1727918	2	SHOCK ABSORBER	
25	1919438	4	NUT, Hex Lock ESNA Light, 5/16-18NC-3B	
26	1919326	1	WASHER, 5/16	
27	1666697	4	SPACER, Powdered Metal	
28	1960723	2	CARRIAGE BOLT, 5/16-18 x 2-1/4, G5	
29	1931277	8	NUT, Hex Flange Whiz Lock, 5/16-18	
31	1727603A	2	PIVOT ASSEMBLY, Control	
32	1728010A	1	BRACKET, R.H. Mounting Handle Pivot	
33	1727927A	1	BRACKET, Tube Mount R.H.	
34	1715025	4	BUSHING	
35	1701342	1	SPRING, Compression	
36	1726839	1	KNOB, Extension Thread, 5/16-18 x 1-1/4	
37	1666106	1	BUSHING, Powdered Metal	
38	1727667	1	BRACKET, Pivot	
39	1922127	1	CAPSCREW, Hex Head, 5/16-18 x 1-3/4, G5	
40	1722460	4	PIN, Quick	

Footnotes:

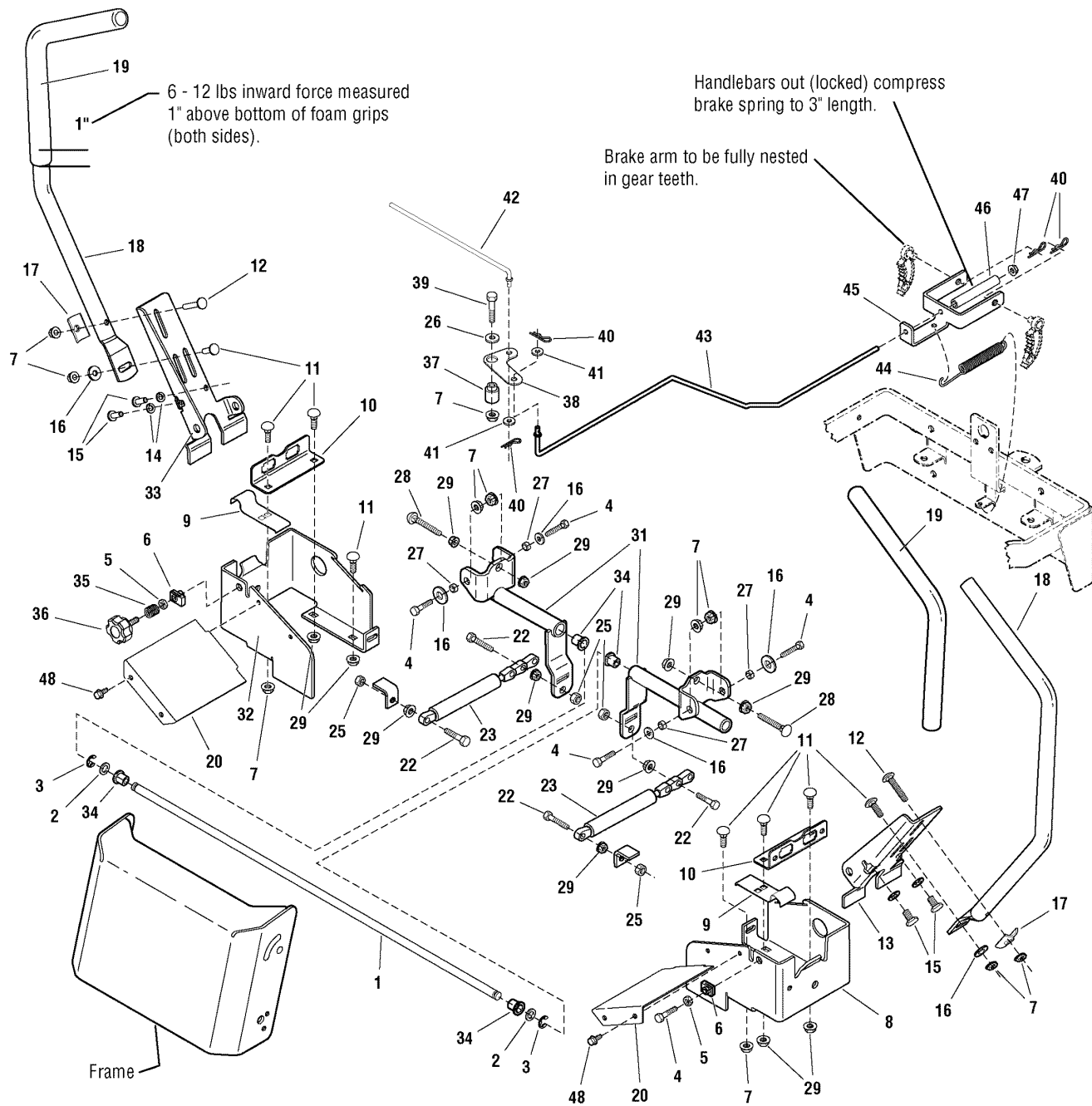

Controls Group

Item	Part No	Qty	Description	Note
41	1921319	2	WASHER, 1/4	
42	1727669	1	ROD, Pivot	
43	1733357	1	ROD, 1/4-20 x 2	
44	1709314	1	SPRING, Extension	
45	1727814A	1	BRACKET, Duel Brake	
46	1729277	1	SPRING, Compression	
47	1960694	1	NUT, Hex Flange, 1/4-20 ESNA	
48	1925003	2	SCREW, Hex Washer Head Taptite, 1/4-20 x 1/2	

Footnotes:

Wheel & Tire Group

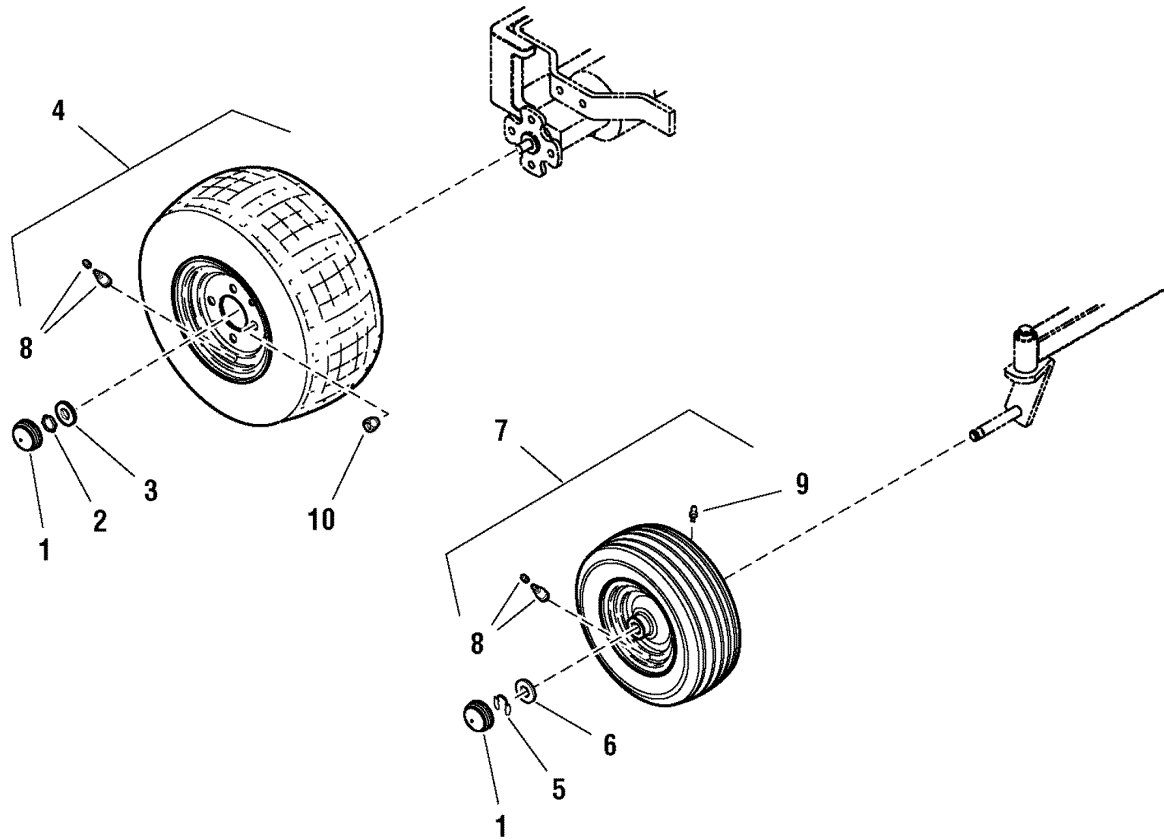

Wheel & Tire Group

Item	Part No	Qty	Description	Note
1	1722675	4	CAP, Hub, 1-1/2 ID Gray Poly 1.3 HI	
2	2830647	2	NUT, Hex Lock Pal, 9/16-18 SAE 1050	
3	2860183	2	WASHER, 3/4, .83 ID x 1.62 OD x .06 THK	
4	1726383	2	WHEEL & TIRE ASSEMBLY, Rear	
5	1611710	2	RING, Klipring for 3/4 DIA Shaft	
6	2860202	2	WASHER, 3/4, 0.76 ID x 1.62 OD x .12 THK	
7	1726382	2	WHEEL & TIRE ASSEMBLY, Front	
8	2172353	2	VALVE STEM & CAP	
9	2812808	2	LUBE FITTING	
10	2177725	12	NUT, Hex Lug, 7/16-20	

Footnotes:

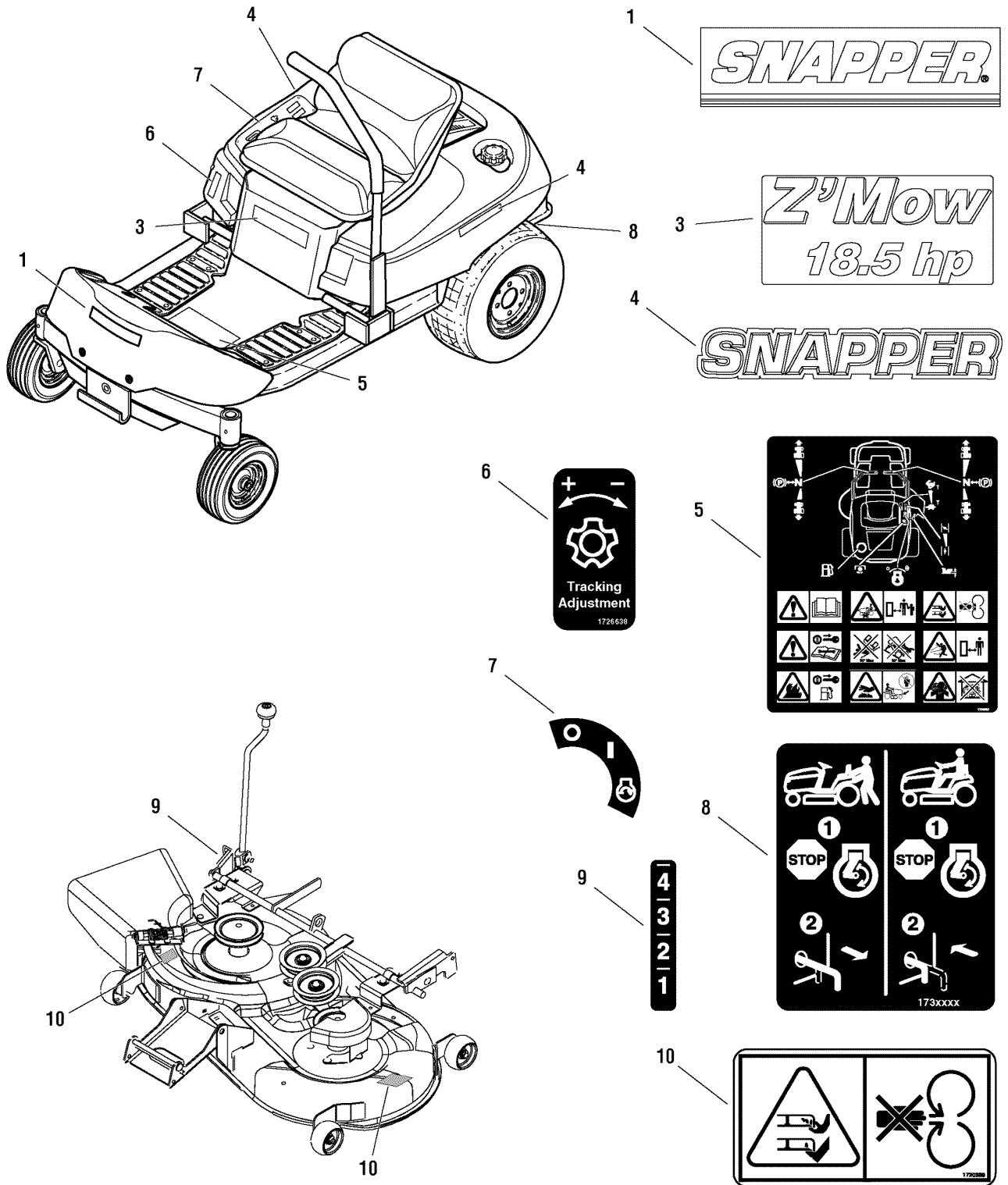

Decals Group

Item	Part No	Qty	Description	Note
1	1731955	1	DECAL, Snapper	
3	1733541	1	DECAL, Snapper, 150Z	
4	7073905	1	DECAL, Snapper Logo	
4	7073905	1	DECAL, Snapper Logo	
5	1733537	1	DECAL, Operating Instructions ZT Export 2007	
6	1726638	1	DECAL, Tracking Adjustment ZT 7000	
7	1722806	1	DECAL, Ignition Switch Symbols White/Black	
8	1730202	2	DECAL, Transmission Tow with Release Lever Hunter	
9	1726642	1	DECAL, 1 2 3 4 HOC	
10	1720389	2	DECAL, Danger Rotating Blade	
	1734233	1	LITERATURE PACK (Not shown)	<i>(Includes Operator's Manual #1733615)</i>

Footnotes:

42" Mower Deck - Clutch & Support Group

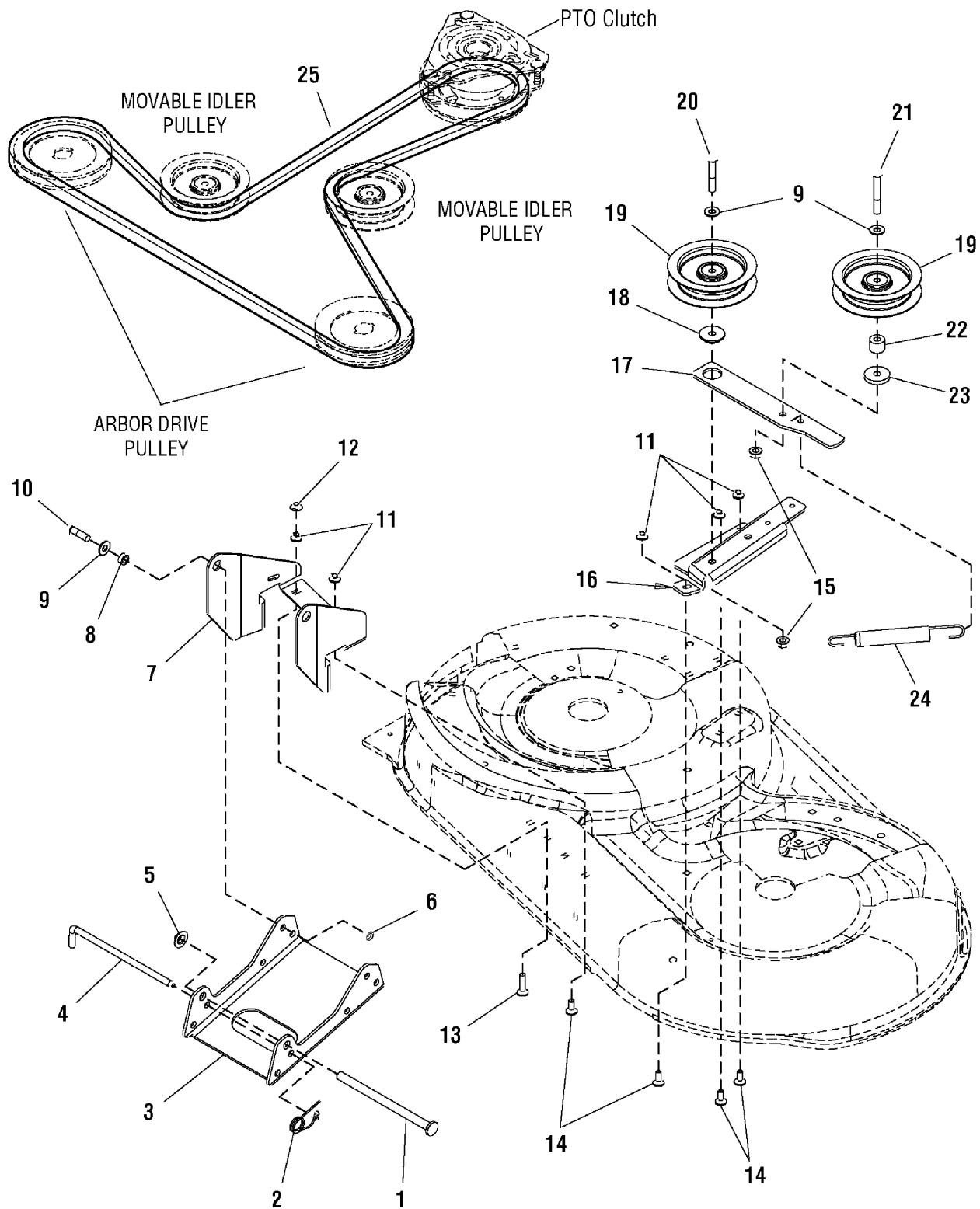

42" Mower Deck - Clutch & Support Group

Item	Part No	Qty	Description	Note
1	1713578	1	ROD, 7-5/8 Long	
2	2176012	1	RETAINER, Pin Spring	
3	1728124A	1	HITCH, Mower	
4	1726012	1	ROD, ZTR	
5	1960519	1	NUT, Push 1/2 Stud Capped	
6	1919439	2	NUT, Hex Lock ESNA Light, 3/8-16 NC3B	
7	1732225D	1	HITCH, Mower Front 42"	
8	2108717	2	SPACER	
9	1924940	4	WASHER, 3/8	
10	1922605	2	CAPSCREW, Hex Head 3/8-16 x 1-1/4, G8	
11	1931277	7	NUT, Hex Whiz Lock Flange, 5/16-18	
12	1935048	1	NUT, Hex Flange Two-Way Lock, 5/16-18	
13	1960223	1	CARRIAGE BOLT, 5/16-18 x 1-1/4, G5	
14	1931333	6	CARRIAGE BOLT, 5/16-18 x 3/4, G5	
15	1931211	2	NUT, Hex Flange Whiz Lock, 3/8-16	
16	1732260D	1	BRACKET, Idler Fixed	
17	1732502A	1	ARM, Idler Clutch	
18	1714255	1	SPACER, Powdered Metal	
19	1732360	2	PULLEY, Idler 4"	
20	1922130	1	CAPSCREW, Hex Head 3/8-16 x 2-1/4, G5	
21	1921973	1	CAPSCREW, Hex Head, 3/8-16 x 2-3/4, G5	
22	1667812	1	SPACER	
23	1960534	1	WASHER, 3/8 Black	
24	1730177	1	Spring, Extension 7-7/8 Long	
25	1734048	1	BELT, HA 103.1 Long	

Footnotes:

42" Mower Deck - Height Adjustment Group

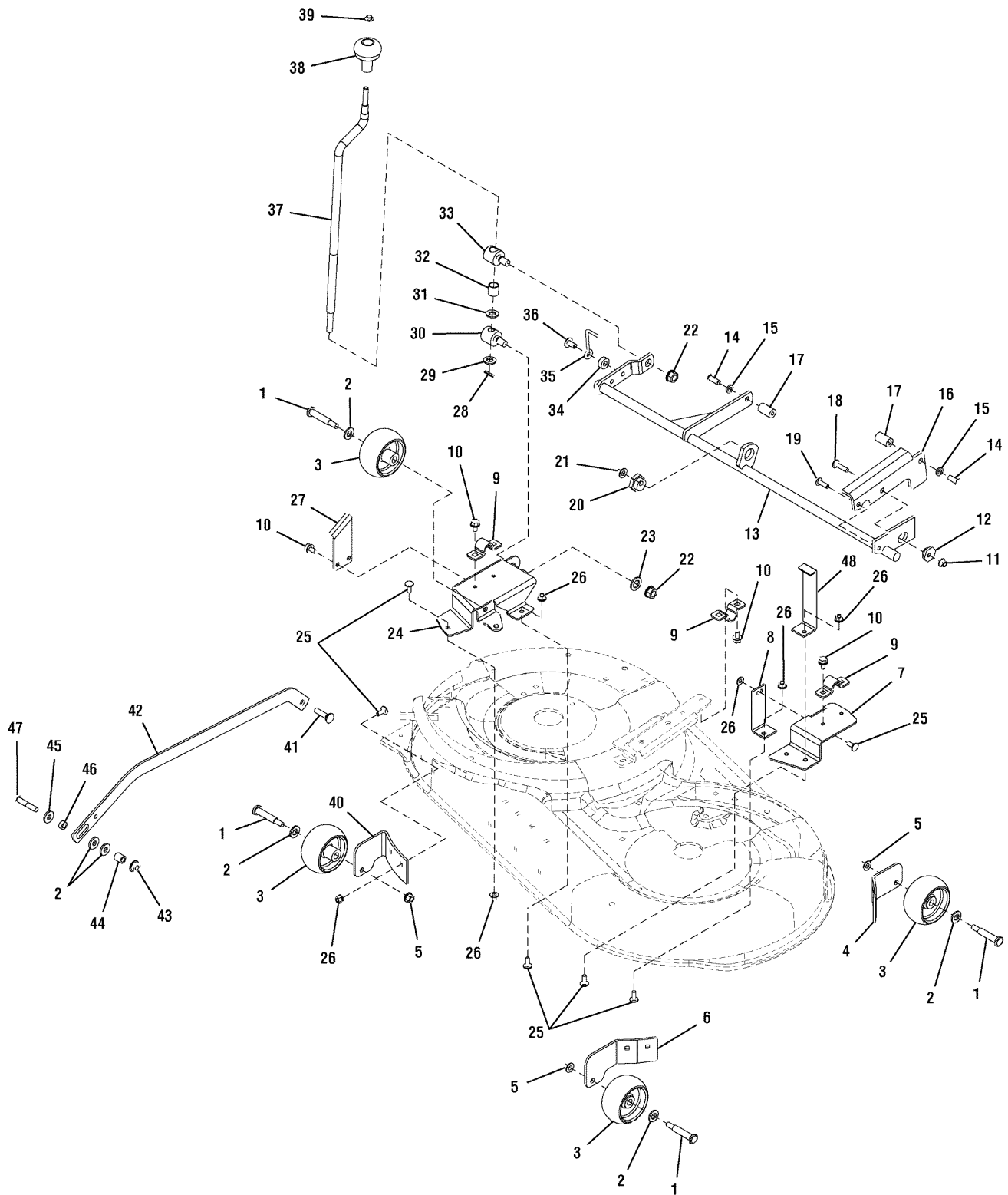

42" Mower Deck - Height Adjustment Group

Item	Part No	Qty	Description	Note
1	2108765	4	BOLT, Wheel, 3/8-16 x 2-25/32 3/4 Thread	
2	1960170	4	WASHER, 1/2	
3	1714760	4	GAUGE WHEEL	
4	1731403D	1	BRACKET, Gauge Wheel LH Back	
5	1960687	4	NUT, Hex Flange ESNA, 3/8-16	
6	1732258D	1	BRACKET, Gauge Wheel LH Front	
7	1732244D	1	BRACKET, Rear LH 42" Glass	
8	1730201D	1	BRACE, Mower 42"	
9	1665374	3	STRAP	
10	1664847	8	CAPSCREW, Hex Washer Head Taptite, 5/16-18 x 3/4	
11	2860643	1	NUT, Hex Flange, 5/16-18 Collar Lock	
12	1714879	1	CAM, Eccentric 1-1/8 A/F Hex	
13	1732279A	1	SHAFT ASSEMBLY, Rocker 42"	
14	1921210	2	CAPSCREW, Hex Head 3/8-16 x 1, G5	
15	1916965	2	LOCKWASHER, Spring 3/8	
16	1718136A	1	ARM, Rear Adjustment	
17	1716010	2	SUPPORT, 1-1/4 Long	
18	1960655	1	CARRIAGE BOLT, 5/16-18 x 1-1/4, G5	
19	1960373	1	CAPSCREW, Hex Washer Head Taptite, 5/16-18 x 1	
20	1704082	1	NUT, Hex Adjusting, .99 DIA .687 TH Powdered Metal	
21	2860681	1	NUT, Hex Toplock Spiral-Lock Flange, 3/8-16	
22	1930644	2	NUT, Hex Flange Two-Way Lock, 1/2-13	
23	1924366	1	WASHER, 5/8	
24	1732243D	1	BRACKET, Rear R.H.	
25	1931333	12	CARRIAGE BOLT, 5/16-18 x 3/4, G5	
26	1931277	12	NUT, Hex Flange Whiz Lock, 5/16-18	
27	1732348D	1	INDICATOR, Cut Height Upstop	
28	2816001	1	PIN, Spring SAE 1095	
29	1704097	1	WASHER, Detent	
30	1732346	1	TRUNNION	
31	1960170	1	WASHER, 1/2	
32	1602946	1	SPACER, Split	
33	1732345	1	TRUNNION	
34	1667811	1	SPACER	
35	1678306	1	INDICATOR, Height of Cut	
36	2827187	1	CAPSCREW, Hex Washer Head Taptite, 3/8-16 x 1	
37	1727681	1	CRANK, Height Adjustment	

Footnotes:

42" Mower Deck - Height Adjustment Group

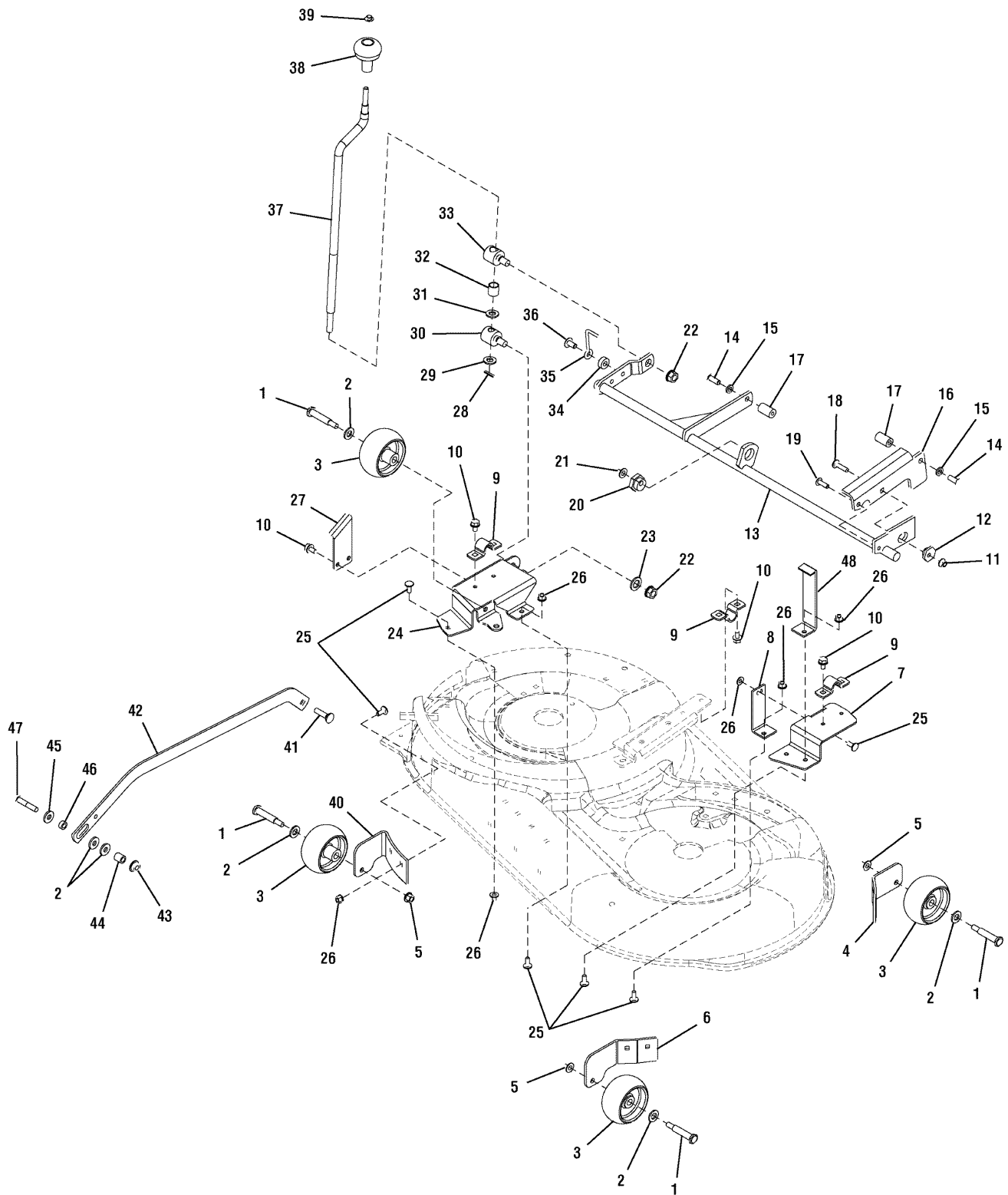

42" Mower Deck - Height Adjustment Group

Item	Part No	Qty	Description	Note
38	1714084	1	KNOB, Spinner	
39	1960093	1	NUT, Push Pal, 3/8	
40	1731402D	1	SUPPORT, Gauge Wheel R.H. Front	
41	1931352	1	CARRIAGE BOLT, 3/8-16 x 1-1/2, G5	
42	1728109A	1	ARM, Pitch	
43	1930645	1	NUT, Hex FlangeTwo-Way Lock, 3/8-16 GA	
44	1674440	1	SPACER	
45	1922755	3	WASHER, 3/8	
46	1611705	1	SPACER	
47	1923701	1	CAPSCREW, Hex Head 3/8-16 x 2, G5	
48	1734111A	1	UPSTOP, 6 x 1-1/4 Bracket	

Footnotes:

42" Mower Deck - Housing & Arbor Group

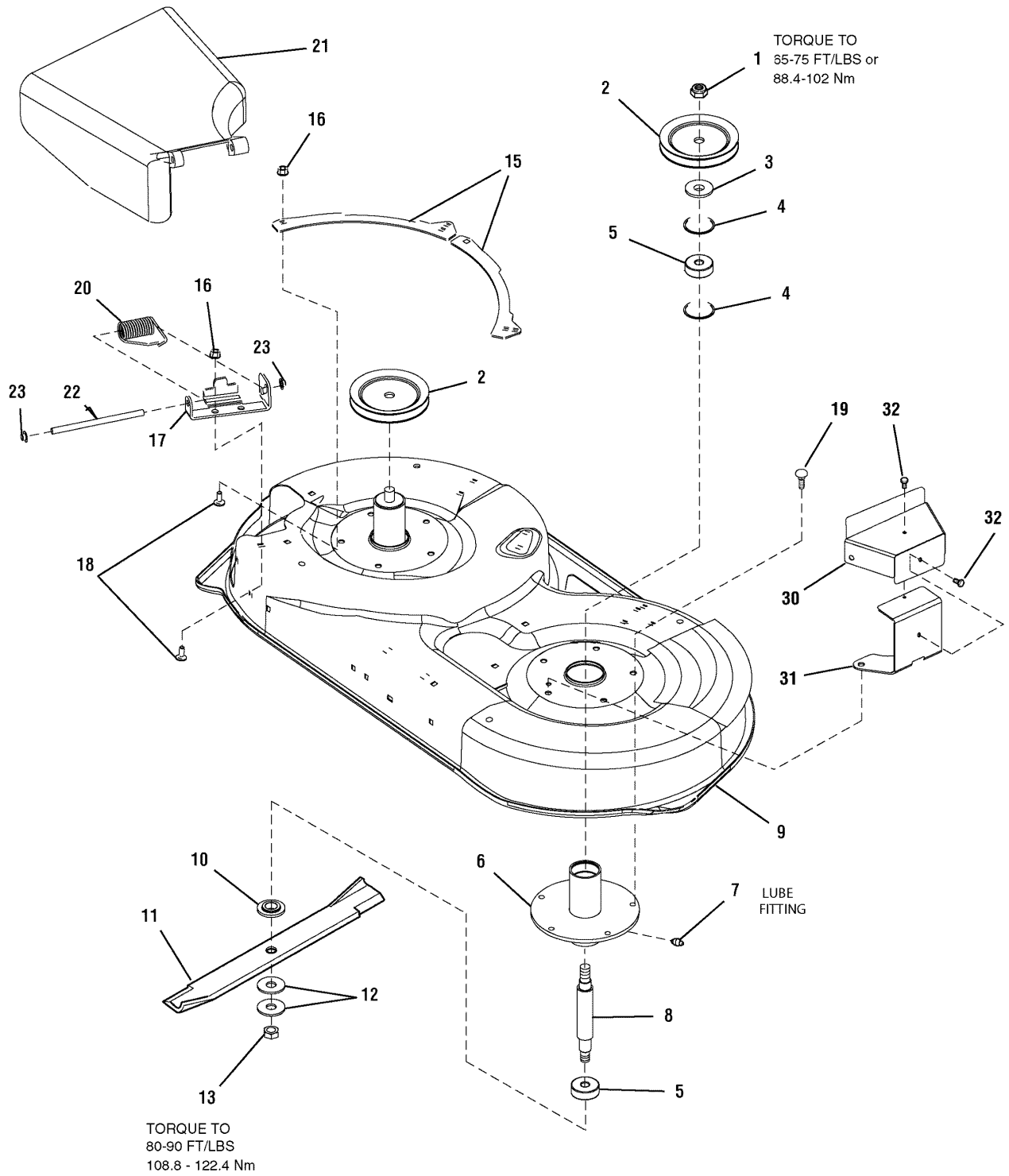

42" Mower Deck - Housing & Arbor Group

Item	Part No	Qty	Description	Note
1	1960576	2	NUT, Hex Lock ESNA Light. 5/8-18	
2	1734064	2	PULLEY, 7"	
3	7072440	2	SPACER, Pulley	
4	7012491	4	RETAINING RING, External 1-3/4	
5	2108202	4	BEARING, Ball	
6	1731372Z	2	TUBE & PLATE ASSEMBLY, Spindle	
7	1704314	2	LUBE FITTING, 1/4 Drive w/Check Ball	
8	7072537	2	SHAFT, Spindle	
9	1687207	1	HOUSING, 42"	
10	1731917	2	WASHER, Spindle Blade, Powdered Metal	
11	1731898A	2	BLADE, Mower 42"	
12	7024467	4	WASHER, Belleville, 1-3/4	
13	7091633	2	NUT, Hex, 9/16	
15	721083A	2	PLATE, Rear 42"	
16	1931277	6	NUT, Hex Flange Whiz Lock, 5/16-18	
17	721369A	2	BRACKET, Hinge	
18	1931333	6	CARRIAGE BOLT, 5/16-18 x 3/4, G5	
19	1923683	10	CAPSCREW, Hex Washer Head Taptite, 3/8-16 x 3/4	
20	720154	1	SPRING, Torsion	
21	721339	1	DEFLECTOR & SUPPORT ASSEMBLY, Chute Riveted	
22	721371	1	ROD, Deflector	
23	1960093	2	NUT, Push Pal, 3/8	
31	1734039A	2	SUPPORT, Pulley Cover	
30	1734035A	2	COVER, Pulley	
32	1924856	4	CAPSCREW, Hex Washer Head Taptite, #10 x 1/2	

Footnotes:

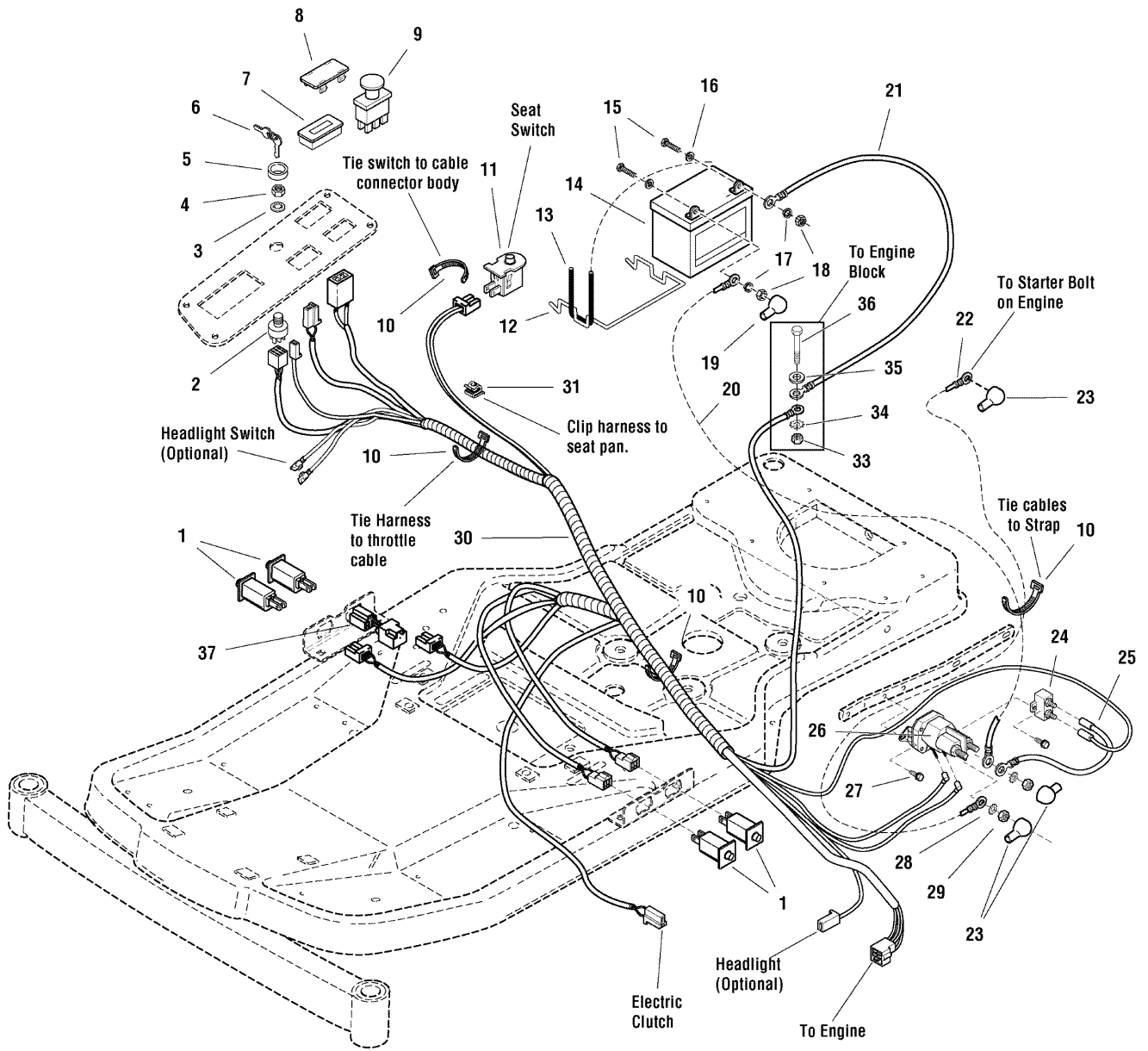

Electrical Group

Item	Part No	Qty	Description	Note
1	1732006	4	SWITCH, Push Button	
2	1686734	1	SWITCH ASSEMBLY, Ignition	(Includes Ref. Nos. 3, 4, 5 & 6)
3	1960547	1	LOCKWASHER, Internal Tooth, Ignition Switch	
4	1717549	1	NUT, Hex Flange, 5/8-32, Ignition Switch	
5	1717550	1	COVER, Ignition Switch	
6	1717163	1	KEYS	(Set of Two Keys)
7	1731185	1	METER, Hour Digital with Oil & Lube Alarms	
8	1722611	1	PLUG, Hole	
9	1722887	1	SWITCH, PTO Push/Pull	
10	2825094	4	TIE, Self Locking	
11	1732005	1	SWITCH, Push Button, Seat Switch	
12	1667805	1	BRACE, Battery	
13	1665872	1	STRAP, Black	
14	1685215	1	BATTERY, 12 Volt, 6 Cell, 340 Amps	
15	2823341	2	CAPSCREW, Hex Head, 1/4-20 x 3/4, G5	
16	2821319	2	WASHER, 1/4	
17	2816964	2	LOCKWASHER, Spring, 1/4	
18	2816622	2	NUT, Hex, 1/4-20	
19	1677296	1	BOOT, Insulator	
20	1716549	1	CABLE, #6 x 10, 2 Ring Terminals	
21	1707056	1	CABLE, #6 x 15, 2 Ring Terminals	
22	1727668	1	CABLE, #6 x 15, 2 Ring Terminals	
23	1724588	3	COVER, Terminal	
24	1665238	1	BREAKER, Circuit, 12 Volt, 20 Amps with Tab	
25	1665237	1	WIRE, 12 GA	
26	1724815	1	SOLENOID, 4 Pole, 12 Volt DC	
27	1925003	2	CAPSCREW, Hex Washer Head Taptite, 1/4-20 x 1/2, G5	
28	2820426	2	LOCKWASHER, External Tooth	
29	2820263	2	NUT, Hex, 5/16-24	
30	1727801	1	HARNESS, Wiring	
31	2172434	1	CLIP, Cable	
33	1931277	1	NUT, Hex Flange Whiz Lock 3/8-18	
34	2820427	1	WASHER, External Tooth, 3/8	
35	1919326	2	WASHER, 5/16	
36	1921221	2	CAPSCREW, Hex Head 5/16-18 x 1-1/2, G5	
37	1734025	1	WIRING ASSEMBLY, Jumper All Conditions Shut-Down	

Footnotes:

Parts Manual for

SNAPPER®

**EUROPEAN ZERO TURN HYDRO DRIVE
18.5 HP 42"
150Z SERIES**

IT IS THE POLICY OF BRIGGS & STRATTON CORP TO IMPROVE ITS PRODUCTS WHENEVER IT IS POSSIBLE AND PRACTICAL TO DO SO. WE RESERVE THE RIGHT TO MAKE CHANGES OR ADD IMPROVEMENTS AT ANY TIME WITHOUT INCURRING ANY OBLIGATION TO MAKE SUCH CHANGES ON PRODUCTS

SNAPPER® McDonough, GA, 30253 U.S.A.